



Biotech

BIOTECH TOP LIGHT

THE FUTURE OF HEATING

TOP LIGHT

Heating with renewable energies is the future and you will not only contribute to the environment, you also will reduce massively your annual energy cost.

The Biotech TOP LIGHT boiler is especially designed to deliver maximum energy to buildings such as:

- Family houses
- Holiday houses
- Small office buildings
- Workshops
- Small warehouses

DCC
dual combustion control*



The Biotech TOP LIGHT heating boiler has a performance range from 2.4 – 9.2 kW and is ideal to serve energy to buildings up to a surface up to 120 m².

With a great nominal efficiency of above 92% the boiler is outstanding in its class and is leading in technology. Key features such as large storage room, daily storage container with an automated transport system, automatic burner and heat exchanger cleaning, lambda probe, micro processor, LED display and so on, are as standard included in the boiler. This for sure will provide you with the highest comfortable levels possible – “enjoy a warm home!”



THE DUAL COMBUSTION CONTROL SYSTEM

The lambda probe is directly placed in the smoke outlet of the appliance and delivers constant data about the rest oxygen of the exhaust gas. In combination with the air mass sensors, the composition of the combustible pellet is recognised automatically and adjusted. In practice the DCC enables a high degree of efficiency and low emission values in every range of performance.



BIOTECH TOP LIGHT

THE FULLY AUTOMATED PELLET HEATING APPLIANCE!

Consisting of:

- ✓ Electric connection: 230 VAC / 50Hz, 16 A
- ✓ Appliance body with efficient winding insulation
- ✓ Automatic ignition of pellets (hot air ignition system)
- ✓ Speed regulated induced draft and secondary air fan
- ✓ Lambda probe and air mass sensors (primary and secondary air)
- ✓ Temperature resistant tubular heat exchanger with automatic cleaning
- ✓ Burning system made of heat resistant stainless steel with automatic burner grate cleaning
- ✓ Daily pellet container including strainer (with notification for fullness) and 1 suction turbines
- ✓ Main Pellets storage room (up to 12 tons) can be within a distance of 15-20 meters away from the appliance
- ✓ Great dimensioned ash box, including as compression (to be emptied after 2-3 tons of burned pellets)
- ✓ Micro processor regulation with graphic screen for menu navigation
- ✓ Up to 4 regulated heating circuits can be activated
- ✓ Assembly and operational manual

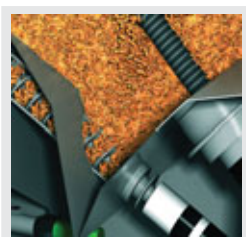

Specific features:

- ✓ Program for hot water tank loading including hot water tank probe, program for accumulator loading is contained in the standard edition
- ✓ Easy placement into heating room as appliance, daily storage container and covering are separate
- ✓ All connections like flow, return flow, ventilation and chimney opening are on top of the heating boiler.

Biotech TOP LIGHT Perfection in detail!

Biotech

- 1 Daily pellet container
- 2 Vacuum flap
- 3 Separator
- 4 Vacuum device
- 5 Worm screw engine
- 6 Worm screw

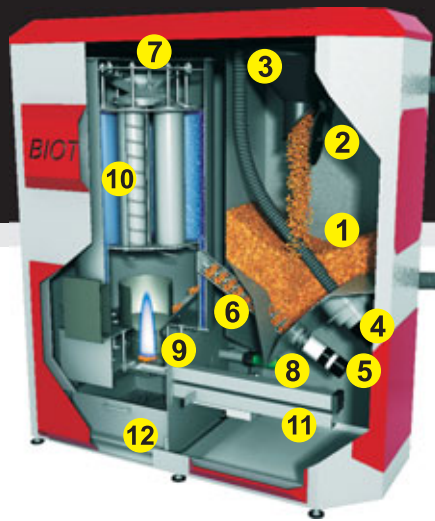

- 7 Lambda probe
- 8 Ignition fan
- 9 Burner grate
- 10 Heat exchanger
- 11 Air flow sensor
- 12 Ash box

SYSTEM TYPE	TL
Nominal heat performance (kW)	9.20
Degree of efficiency at full load (%)	92.00
Degree of efficiency at part load (%)	92.20
Max.adjustable boiler temperature (°C)	80
Tolerable operating pressure (bar)	3
CE designation according to low tension guidelines	CE

DIMENSIONS	TL
Width boiler (mm)	900
Depth boiler (mm)	480
Total depth (mm)	620 ²⁾
Height of boiler (mm)	1400 ¹⁾
Height of smoke tube connection (mm)	1450 ¹⁾
Height of flow (mm)	1435 ¹⁾
Height of return flow (mm)	1435 ¹⁾
Height of ventilation (mm)	1435 ¹⁾
Diameter of smoke tube connection (mm)	130
Total weight (kg)	245
Water content (lt)	25
Reservoir – automatically useable (kg)	27
Ash box – useable (lt)	13

CONNECTIONS	TL
Flow (inch)	¾
Return flow (inch)	¾
Ventilation for boiler (inch)	½
Appliance emptying (inch)	½

HEATING WATER FLOW RESISTANCE	TL
ΔT = 20K (mbar)	-
ΔT = 10K (mbar)	-

EXHAUST GAS VALUE	TL
Exhaust gas temperature at full load (°C)	95.00
Exhaust gas temperature at part load (°C)	54.00
Exhaust gas mass flow at full load (g/s)	5.3
Exhaust gas mass flow at part load (g/s)	1.8
CO2 at full load (Vol%)	13.10
CO2 at part load (Vol%)	10.50
Necessary delivery pressure (mbar/Pa)	0.00-0.05/0-5

ELECTRIC POWER INPUT	TL
Standby (W)	20
Filling – Turbine (W)	1600
Great cleaning (W)	65
Pre-filling (W)	75
Ignition (W)	1020
At 100% performance (W)	50-80

MINIMUM DISTANCES TO WALLS	TL
Backward (mm)	-
Left to wall (mm)	-
Right to walls (mm)	400

VOLUME	TL
In operation (DB)	35
During suction (DB)	67

1) Excl. adjustable feet; 2) Incl. exhaust gas pipe



Pellets consumption:

- Minimum 0.5 kg/h
- Maximum 1.9 kg/h at full capacity

Planning
the necessary space!

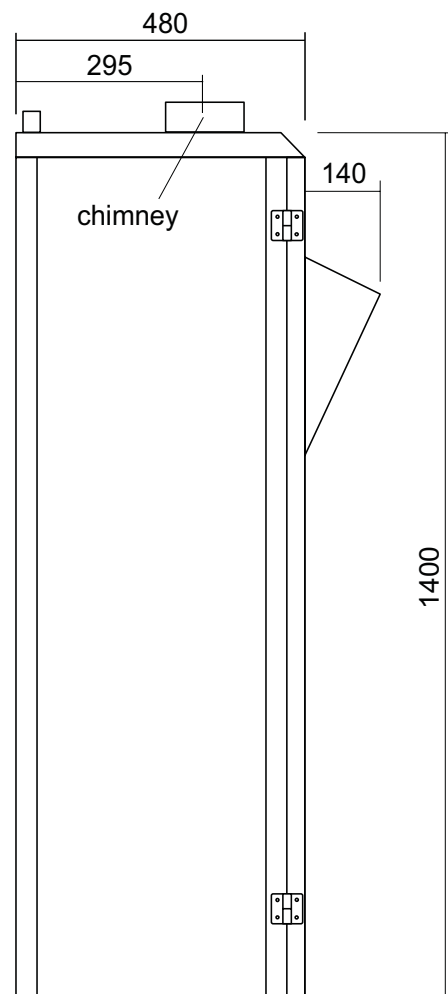
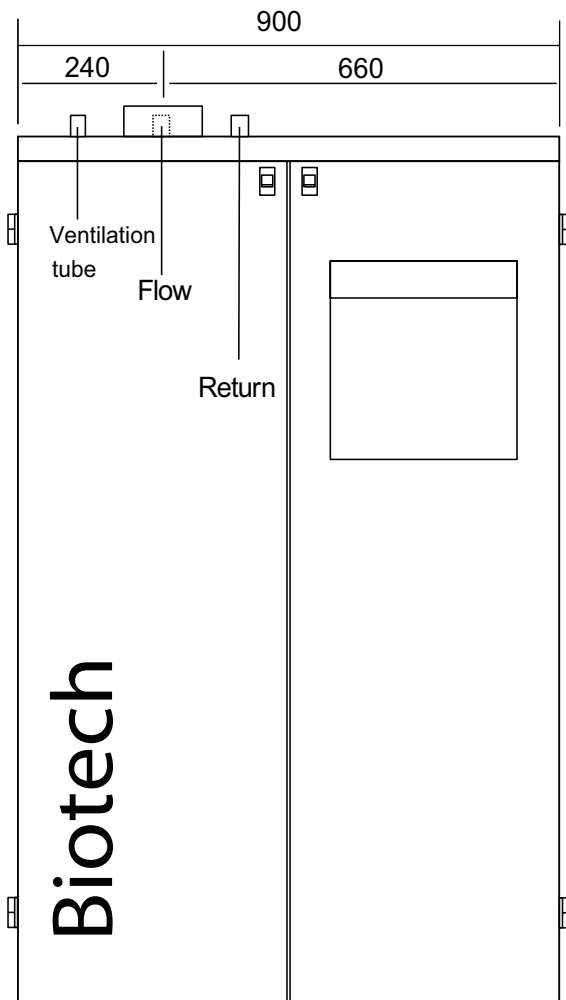
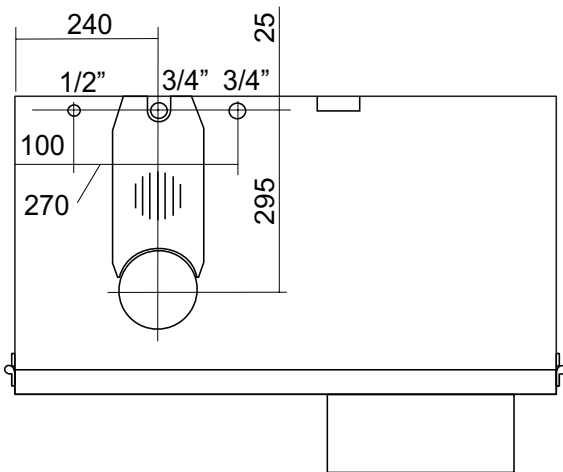



Biotech

The complete solutions
from the expert!



min. 297 cm
max. 316 cm

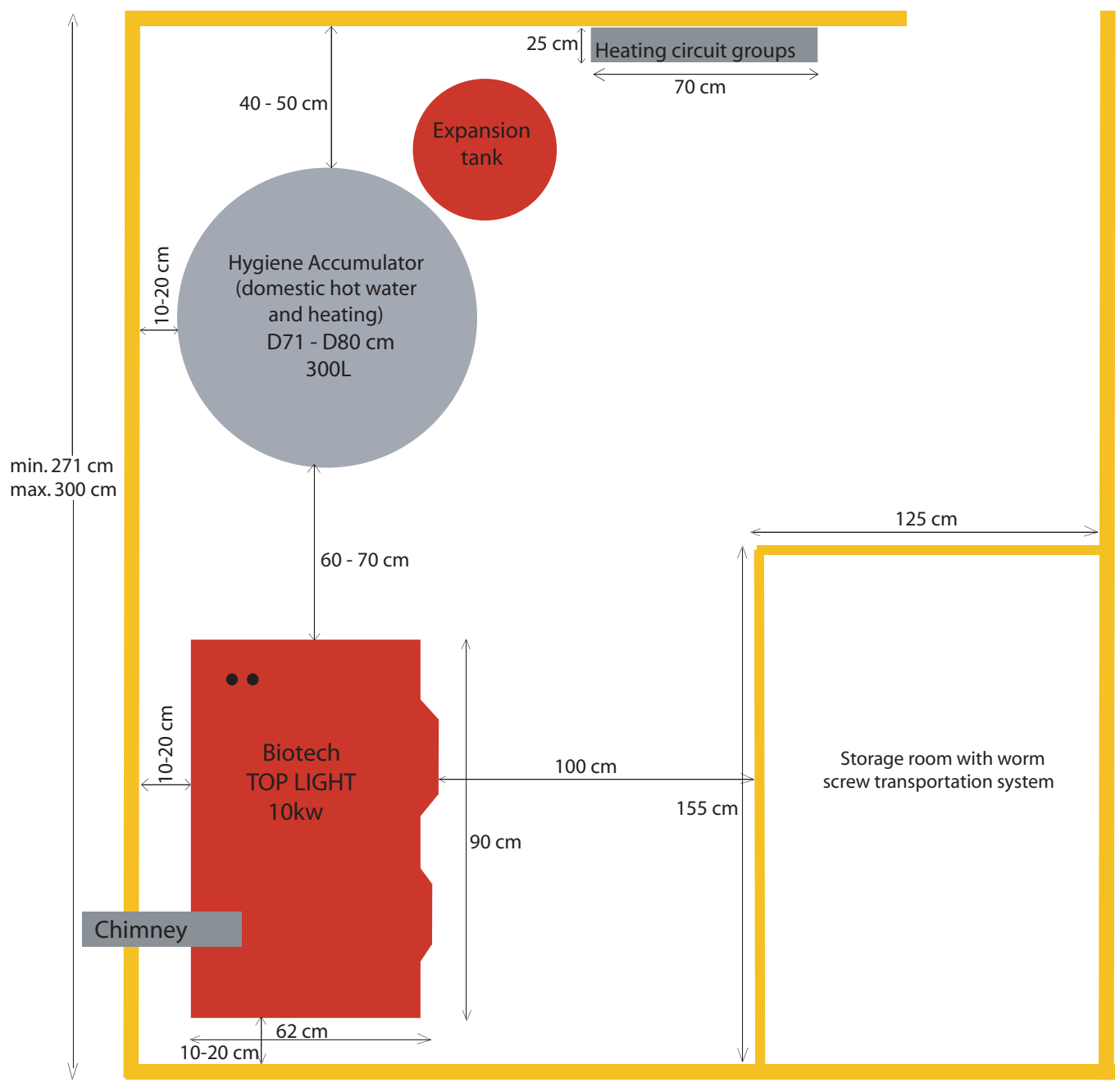

* On one of the three walls will be an air inlet window



For further information please contact us !



for you, for the environment

S.C. CALIDUS SRL

Straulesti Road No. 154, District 1, 013339

Bucharest, Romania

Tel.: +40 (0)21.409.29.92, Fax: +40 (0)21.409.29.94

PELETTI